



Onboard toilets and accessories



TM Company



TM – Company

The owner-run family business **TM** Technischer Gerätebau GmbH was originally developed from an electrical wholesalers which still exists to this day. The company, which was officially launched by Hermann Fixl in 1991, started off by constructing cool boxes for the automotive industry and developed into what it is today. **TM** has its headquarters in Neu-Ulm and is now run by the fourth generation of the founding family.

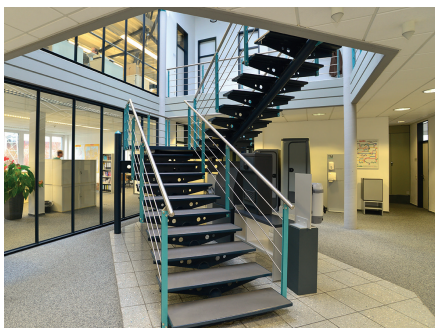

TM – Specialist

Known as a refrigeration and small-scale assembly specialist, **TM** perfectly serves its niche markets in particular. Product solutions are designed and implemented in-house and independently or manufactured according to the customer's detailed specifications.



Our products are used in mobile as well as static installations. Speed, flexibility and many years of experience in manufacturing and development make the company a strong and reliable partner in the industry.

TM – Products

Since its founding, **TM** has been producing components for mobile passenger services, mainly used in buses as well as in trucks and rail vehicles. **TM** has developed product solutions for a wide range of applications over the years and has firmly established itself in a wide range of industries such as, for example, in the field of fully automatic coffee machines.

The wide-ranging product portfolio includes the classic dashboard cool box, board kitchens and toilets for the bus industry as well as milk coolers for coffee machines, and many more.

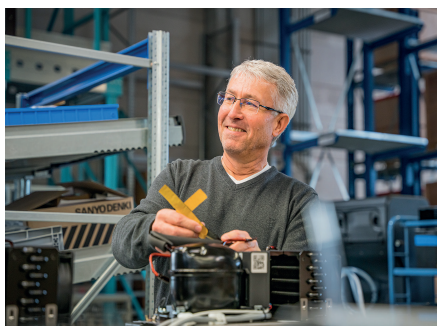

TM – International

In 2007, **TM** established a subsidiary company near Istanbul to respond to increasing globalisation and the integration of markets. **TM-Turkey** mainly operates in the expanding bus and truck sector in its home market, as well as in neighbouring Arab countries.

In the same year, Jincen-**TM** was established as a joint venture company in China's Anhui Province to serve the Chinese market and to create more synergies. The Chinese company is mainly focused on producing injection moulded parts for the automotive, electrical and household industries as well as assembling on-board kitchens and cool boxes.

Being close to our customers and quick response times are of paramount importance for **TM** so our customers can rely on a Europe-wide network of service partners. **TM** can guarantee a seamless and fast on-site service through the continuous expansion of our partners.



TM – Philosophy

TM Technischer Gerätebau GmbH is a family-run business, distinguished by our short and direct lines of communication, as well as continuity.

From product design, through quality assurance of the materials used, right up to the final product test, we place the highest value on the perfect processing and precision of our products. Naturally, our products are certified according to relevant EU directives as well as our quality management system being certified according to ISO guidelines.

TM – Customer Satisfaction

Innovative concepts to a high technical standard, together with excellent materials and processing quality, create outstanding products. Our product solutions are constantly setting new standards due to their functionality, compact dimensions and attractive design.

Experience, reliability, quality and long-term success are the building blocks of the current product range and the foundation for satisfied customers throughout the world.





On the way home



TM Onboard toilets

We have a wide variety of onboard toilets for you to choose from.
We are happy to advise you - ask our specialists!

Onboard toilet available over-the-counter

TM Toilet cubicles

Odourless due to a microbiological procedure.
Fresh water flushing with TM Aqua Flush without chemical additives.

When developing our onboard toilets for coaches, we focus on the wishes of bus manufacturers and bus operators, but also on the needs of passengers.

Our durable toilet cubicles stand out due to their high-quality components. They are particularly user-friendly and easy to clean. All components are easily accessible and enable fast maintenance and service.

The standard model of the onboard toilets is covered on the outside with a low-maintenance, durable PVC material. Effective fresh water flushing is achieved through the especially low-maintenance TM Aqua Flush system. Its electronic control makes the system particularly economical for water consumption. Odour in the cubicle is prevented due to a microbiological procedure. Without any chemical additives. The cubicle functions can be monitored from the dashboard.



Onboard toilet available over-the-counter

Central access toilet

The toilet for installation in the centre bus area.

The central access toilet is specially designed for installation at the bus's middle entrance. Due to its slanted rear wall, the spacious toilet cubicle fits perfectly behind the passenger seats.

Central access toilet

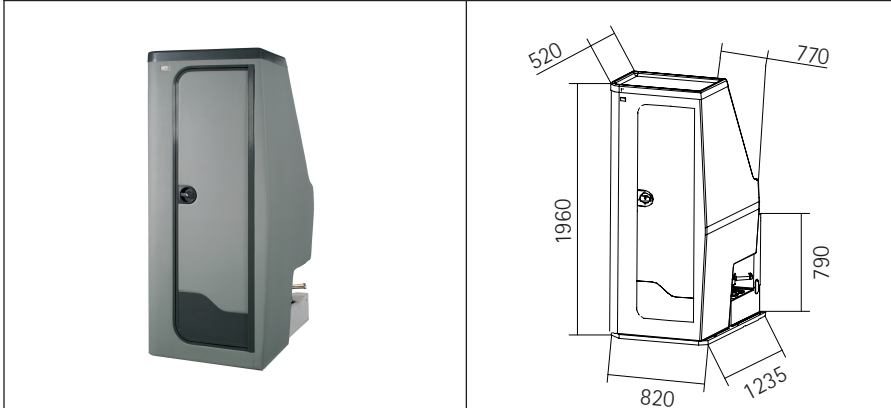

scope of delivery:

- central access toilet

standard equipment:

- GRP model with yellow coated inner wall - colour blue-grey
- external cladding made of durable PVC material
- door with security lock, opens outwards, with 1/3-opening hinge mechanism and automatic door closure
- passive infrared motion sensor
- holding handle inside the cubicle
- alarm button, smoke alarm
- wash basin with time-regulated water outlet and splash-proof push button
- soap dispenser, paper towel dispenser, mirror made of safety glass, toilet roll holder, waste bin with spring-loaded lid
- TM Aqua Flush
- control valves
- extractor fan
- waste water tank, fresh water tank
- service hatch
- "free", "busy" and "faulty" status sign on the outside of the cubicle
- can be operated in winter

order no.:

09.1000.00.00 standard equipment with soap dispenser, paper towel dispenser

voltage: 24 V DC

power: 700 W

current consumption: 30,0 A

waste water tank: 80 l

flushing: 0,5 l

weight: 147 kg

other versions:

09.1050.00.00 electric hand dryer

accessories:

further colour variants

32.1000.10.08 electric hand dryer

30.6000.00.11 electro-pneumatic valve, waste water tank

09.1000.61.12 smoke alarm

16.1000.00.00 fresh water tank

The central access toilets meets the following guidelines and certifications:

- EMV Directive ECE R10
- Fire behaviour per regulation ECE R118

Additional extras for central access toilet under the accessories category.

interior toilet cubicle



exterior surface material



waste water tank and technics



Onboard toilet available over-the-counter

Rear access toilet

The onboard toilet for installation in the rear bus area.

The rear access toilet is specially designed for installation at the narrower rear-end of the bus. Despite its compact size, the rear toilet offers ample space.

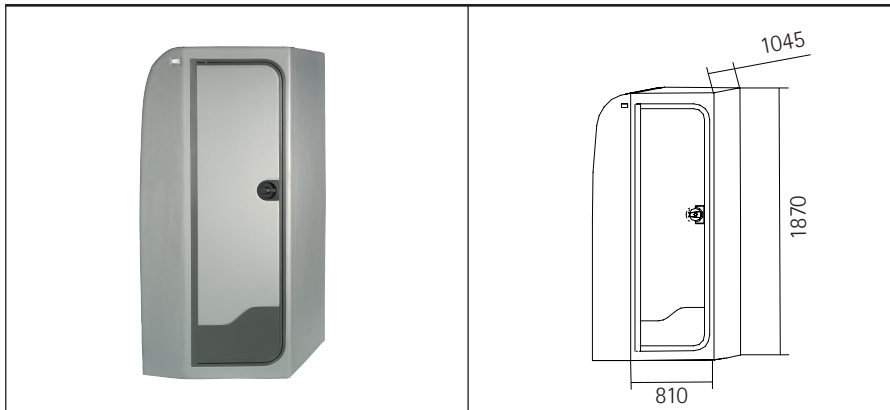

Rear access toilet

order no.:	
09.1500.00.00	standard equipment with soap dispenser, paper towel dispenser
voltage:	24 V DC
power:	700 W
current consumption:	30,0 A
waste water tank:	80 l
flushing:	0,5 l
weight:	163 kg

scope of delivery:

- rear access toilet

standard equipment:

- GRP model with yellow coated inner wall - colour blue-grey
- external cladding made of durable PVC material
- door with security lock, opens outwards, with 1/3-opening hinge mechanism and automatic door closure
- passive infrared motion sensor
- holding handle inside the cubicle
- alarm button, smoke alarm
- wash basin with time-regulated water outlet and splash-proof push button
- soap dispenser, paper towel dispenser, mirror made of safety glass, toilet roll holder, waste bin with spring-loaded lid
- TM Aqua Flush
- control valves
- extractor fan
- waste water tank
- service hatch
- "free", "busy" and "faulty" status sign on the outside of the cubicle
- can be operated in winter

The central access toilets meets the following guidelines and certifications:

- EMV Directive ECE R10
- Fire behaviour per regulation ECE R118

other versions:

- 09.1501.00.00 electric soap dispenser, paper towel holder
- 09.1550.00.00 soap dispenser, electric hand dryer
- 09.1551.00.00 electric soap dispenser, electric hand dryer

accessories:

- further colour variants
- 09.1000.80.05 cabin cover
- 32.1000.10.08 electric hand dryer
- 30.6000.00.11 electro-pneumatic valve, waste water tank
- 09.1000.61.12 smoke alarm
- 16.1000.00.00 fresh water tank

Additional extras for rear access toilet under the accessories category.

Onboard toilet available over-the-counter

TM AquaFlush

Fresh water flushing without chemical additives.
Odour development is prevented by a microbiological procedure.
Suitable for toilet conversion and retrofitting, as well as for a DIY build.

TM Aqua Flush freshwater flushing is a fresh water flushing system for onboard toilets which has been developed with tried-and-tested components and state-of-the-art technology for heavy commercial use in coaches.
Long-term reliability, effective flushing operation and easy accessibility for servicing are the distinguishing features of this system.

TM Aqua Flush is available in different models.
The system can be modified to suit the location and the customer's requirements and can also be retrofitted to existing toilet cubicles.

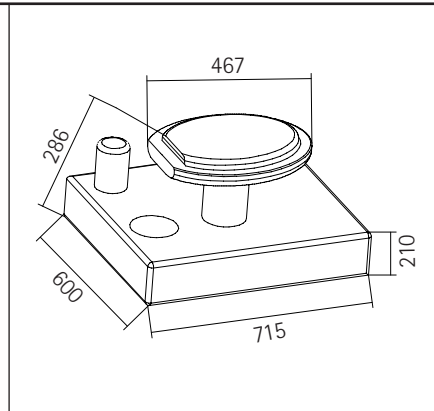

TM AquaFlush

order no.:	
09.0001.00.00	standard equipment „Basic“
voltage:	24 V DC
power:	90 W
current consumption:	3,8 A
waste water tank:	80 l
flushing:	0,5 l
weight:	30 kg

scope of delivery:

- TM AquaFlush

standard equipment „Basic“:

- removable toilet bowl with cover
- durable toilet seat
- adapter flange
- Shurflo water pump
- water filter
- control valves
- fastening set
- can be operated in winter

equipment model „Electric“:

- 09.0001.00.10 „Electric“
- standard equipment „Basic“ with electronic system
- printed circuit board with connecting cable
- infrared motion sensor

equipment model „Complete“:

- 09.0001.00.20 „Complete“
- standard equipment „Basic“ with electronic system
- waste water tank with connector set
- waste water tank fan
- electro-pneumatic evacuation valve

Additional extras for TM AquaFlush under the accessories category.

Onboard toilet customer-specific

Van Hool toilet cubicle

The water toilet with optimised features for more passenger comfort.

In order to further optimise the tried and tested Van Hool toilet cubicle, to implement improvements and customer requests more quickly and to get a continuous overview of quality standards, we have relocated the assembly of this onboard toilet to our site in Neu-Ulm/Germany.

The toilet cubicle consists of a housing base including equipment, a service hatch for better access to the technical panel as well as tank components consisting of two fresh water tanks and a waste water tank.

Van Hool toilet cubicle

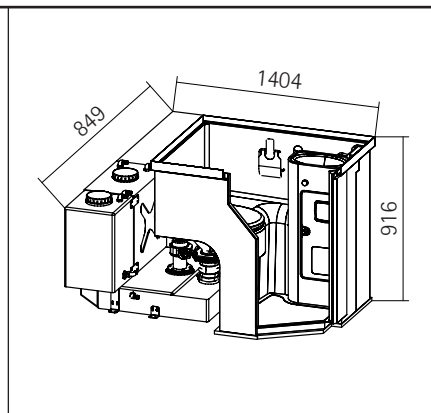

order no.:

09.3004.00.09

voltage: 24 V DC

power: 60 W

current consumption: 2,5 A

waste water tank: 60 l

flushing: 0,4 l

weight: 65 kg

scope of delivery:

- Van Hool toilet cubicle

standard equipment:

- durable toilet seat
- alarm button
- wash basin with time-regulated water outlet and splash-proof push button
- waste container
- extractor fan
- 2 fresh water tanks
- 1 waste water tank
- service flap
- adapter flange
- pump
- control valves
- water filter

- fastening set
- can be operated in winter

The Van Hool toilet cubicle meets the following guidelines and certifications:

- EMV Directive ECE R10
- Fire behaviour per regulation ECE R118
- Drinking Water Ordinance DIN 2001

Additional extras for Van Hool toilet cubicle under the accessories category.

top view toilet cubicle

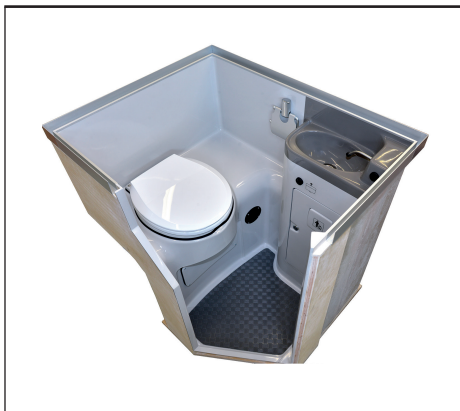

tank unit



rear side tank unit with sliding valve



On the way home



TM Accessories

We have a wide variety of accessories for you to choose from.
We are happy to advise you – ask our specialists!

Water tanks

Fresh water tanks 86 and 140 litres

As a retrofit kit for our toilet systems.

All water tanks are made of polyethene, as well as being resistant to pressure and impact.

Fresh water tank 86 l

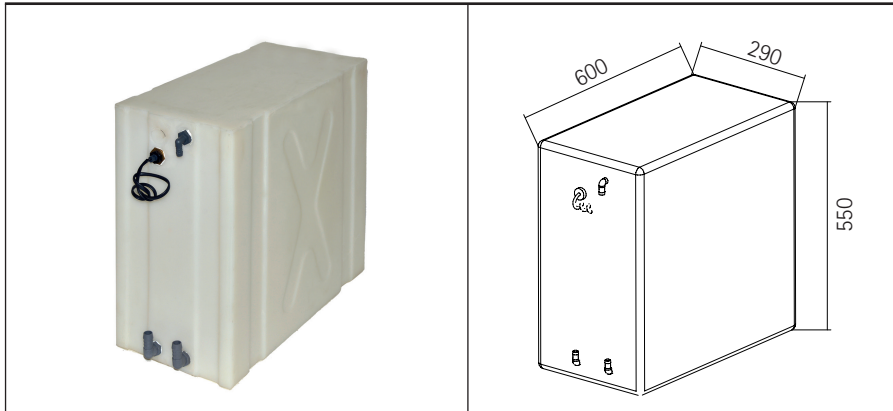

order no.:

16.1000.00.02

volume: 86 l

Fresh water tank 140 l

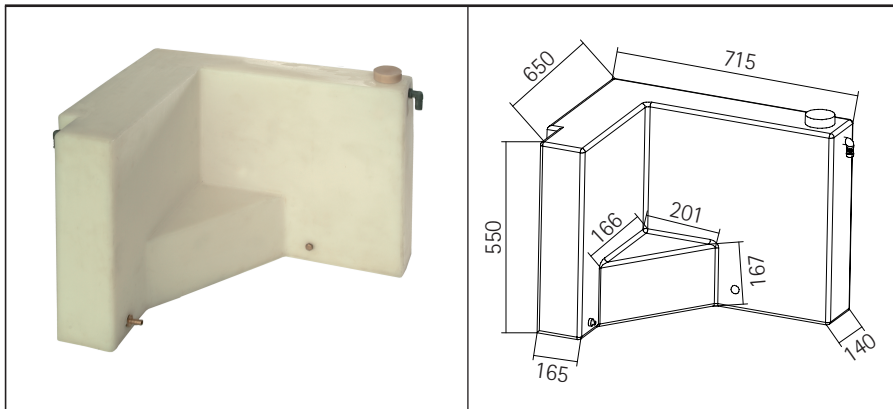

order no.:

16.1000.00.00

volume: 140 l

Paper towel dispenser

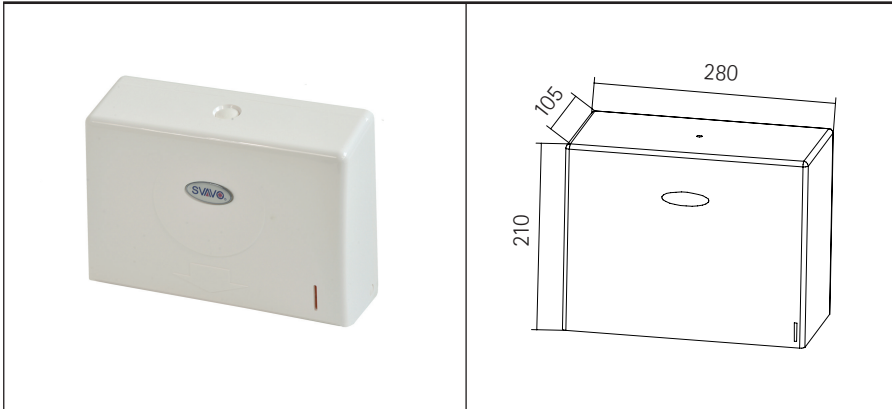

order no.:

52.1000.40.02

Hand dryer

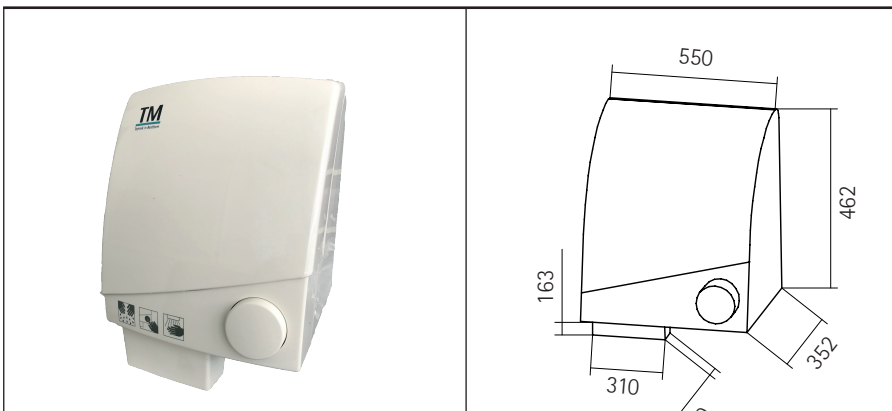

order no.:

32.1000.10.09

voltage: 24 V DC

power: 700 W

current consumption: 32,0 A

Radio smoke detector

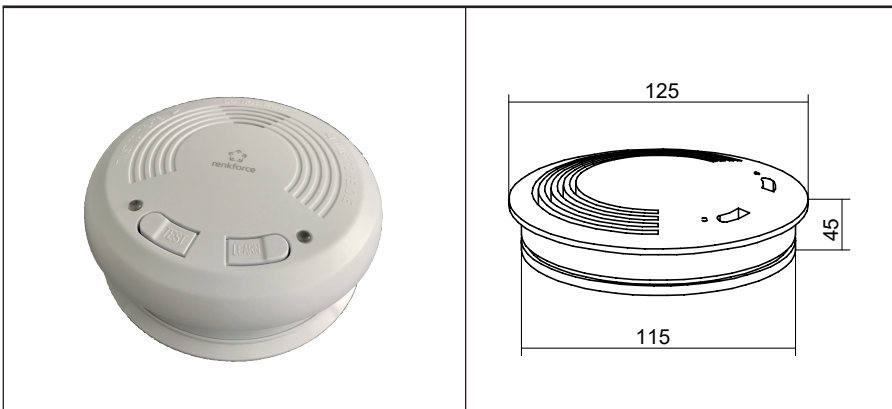

order no.:

09.1000.61.12

scope of delivery:

- radio smoke detector (can be networked via radio with other smoke detectors)
- batteries

equipment:

- acoustic alarm with 85 dB volume
- emergency LED lighting on alarm activation
- self-test and battery monitoring function
- bidirectional radio protocol for high transmission reliability and status reporting

Pressure water pumps

Pressure water pump 12 and 24 V

High performance for an even water flow.

Pressurised water pumps ensure an even flow of water in the onboard toilet and guarantee optimum flushing results.

The pump automatically detects whether a tap is open or closed via a built-in pressure monitoring switch. Accordingly, it switches itself on and off automatically.

The required amount of water is monitored electronically. This determines the required motor speed and controls it electronically.

Flojet water pump 24 V

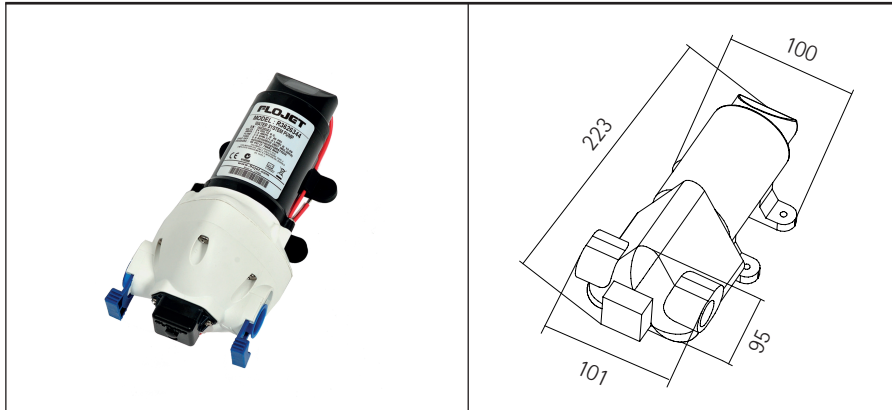

order no.:	
	05.6000.02.00
voltage:	24 V DC
power:	52,8 W
current consumption:	2,2 A maximum
output:	11 l / min. maximum
cut-off pressure:	2,8 bar
weight:	1,59 kg

Shurflo water pump 12/24 V

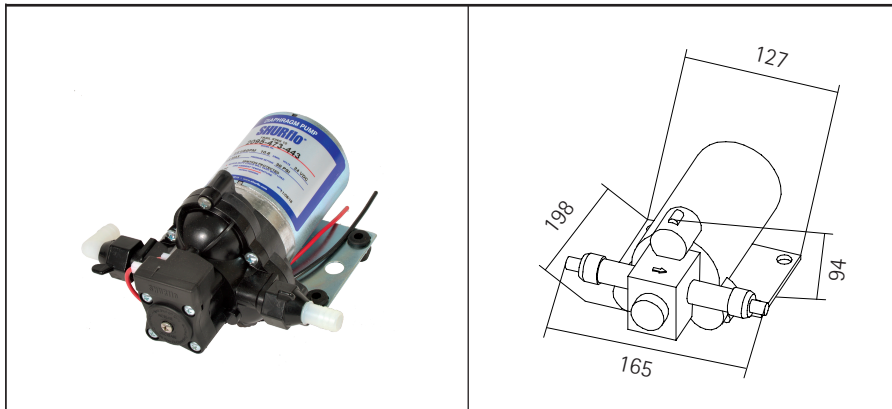

order no.:	
	05.6000.01.02 (12 V)
voltage:	12 V DC
power:	78 W
current consumption:	6,5 A
output:	10,6 l / min. maximum
reclosing pressure:	2 – 3,2 bar adjustable
weight:	1,8 kg

order no.:	
	05.6000.00.02 (24 V)
voltage:	24 V DC
power:	96 W
current consumption:	4,0 A
output:	10,6 l / min. maximum
cut-off pressure:	2,1 bar
weight:	1,8 kg

Sliding valves

Manual and pneumatic sliding valves

For easy opening and closing of the toilet slider.

Using sliding valves in toilets has become a tried-and-tested, well-established system. In addition to the toilet outlet opening, the drainage opening of the waste water tank is also controlled manually or pneumatically via a sliding valve.

Manual sliding valve

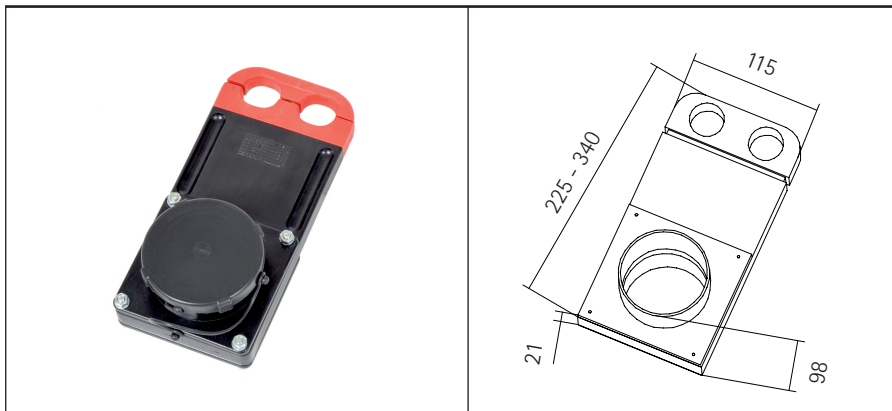

order no.:

30.6000.00.10

Pneumatic sliding valve

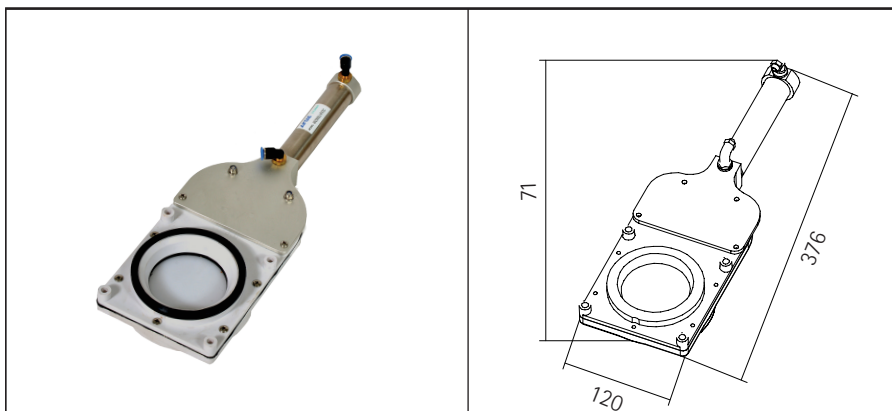

order no.:

30.6000.00.11

Mobileclean central vacuum cleaner

Suitable for installation in minibuses, midibuses, coaches and camper vans.

The Mobileclean central vacuum cleaner guarantees fast and effective cleaning of the vehicle interior. Thanks to the accessories included in the set, not only the floor but also seats, upholstery, fittings and grooves can be cleaned.

The space-saving rectangular design allows the central vacuum cleaner to be optimally installed in the luggage compartment or storage space near the rear entrance area of a vehicle. The suction socket is placed on one of the vertical surfaces of the steps, side-ways at the entrance or in the longitudinal aisle of the bus.

Mobileclean central vacuum cleaner 12/24 V

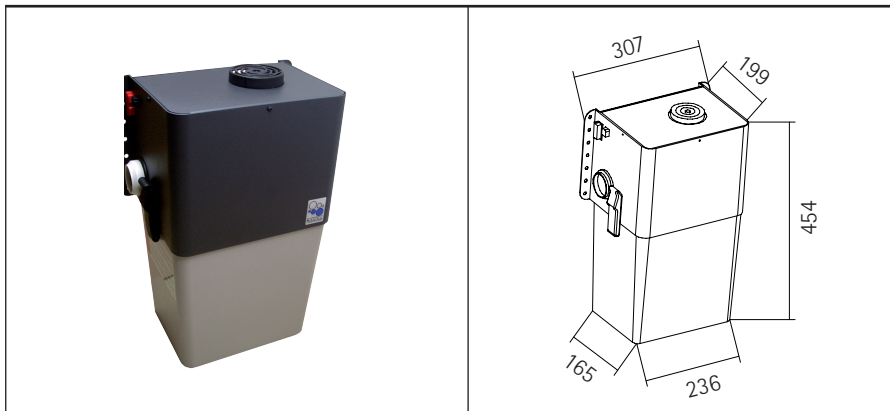

order no.:	12 V
22.0000.14.00	M12S5C suction hose 5 m
22.0000.15.00	M12S6 suction hose 6 m
22.0000.16.00	B12S5C suction hose 5 m
22.0000.17.00	B12S6 suction hose 6 m

voltage:	12 V DC
power:	450 W
current consumption:	37 A
fuse protection:	40,0 A
vacuum:	110 mbar
air volume:	26 l/sec.
motor:	two-stage turbine with separate engine air cooling
filter:	washable polyester fleece
volume:	29 l
weight:	14,5 kg

The minimum order quantity is 50 pieces for the 12 V variants!

order no.:	24 V
22.0000.10.00	M24S7 suction hose 7,5 m
22.0000.11.00	M24S10 suction hose 10 m
22.0000.12.00	B24S7 suction hose 7,5 m
22.0000.13.00	B24S10 suction hose 10 m

voltage:	24 V DC
power:	550 – 650 W
current consumption:	24 – 27 A
fuse protection:	40,0 A
vacuum:	170 mbar
air volume:	36 – 45 l/sec.
motor:	two-stage turbine with separate engine air cooling
filter:	washable polyester fleece
volume:	29 l
weight:	14,5 kg

scope of delivery:

- Central vacuum cleaner
- Electrical connections and control cables
- Suction socket with connecting pipe to the vacuum cleaner
- Suction hose up to 7.5 or 10 m
- Vacuum cleaner accessories: Floor nozzle, upholstery nozzle, groove nozzle and brush
- Operating and installation instructions (DE, GB, IT)
- Transport containers
- Robust plastic container for storing vacuum cleaning accessories

The set does not include the four installation screws for mounting the vacuum cleaner and the electrical power supply, as these are different for all vehicle types.

equipment model M12:

- electronic motor control
- built-in battery monitor
- Control unit for monitoring current, temperature and mains voltage.

equipment model B12:

- electromechanical motor control

The on/off switch is located directly on the device, where the control plug of the suction socket is normally installed. This option is available in combination with Set 5C. Option C is recommended for vehicles that do not have a separate boot and therefore need to install the vacuum cleaner inside.

The suction hose is wound directly on the hose holder next to the device.

equipment model M24:

- electronic motor control
- built-in battery monitor
- Control unit for monitoring current, temperature and mains voltage.

equipment model B24:

- electromechanical motor control

mounting situation in the bus

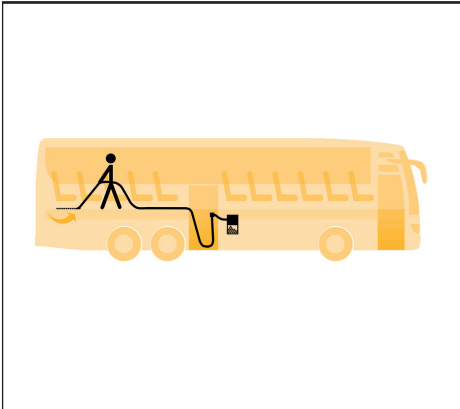

mounting example vacuum cleaner



mounting example socket



Bus phone

Suitable for installation in buses, yachts and camper vans.

The handy bus phone with an intercom system in an elegant design provides a direct line between the tour guide and passengers. Suitable for parallel connection of up to 3 bus phone stations.

Bus phone 12/24 V

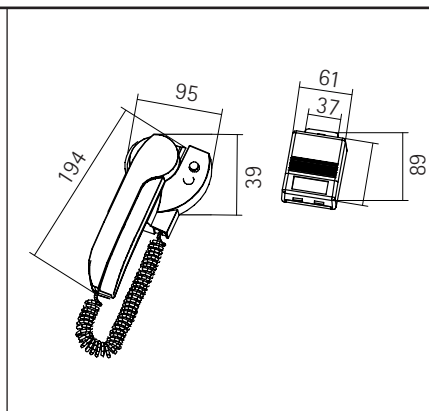

order no.:	12 V
13.6002.12.00	
voltage:	12 V DC
power:	0,84 W maximum
current consumption:	70 mA maximum
weight:	0,3 kg
order no.:	24 V
13.6002.24.00	
voltage:	24 V DC
power:	1,7 W maximum
current consumption:	70 mA maximum
weight:	0,3 kg

scope of delivery:

- 2 bus phone stations with handset
- mains socket 12-24 V
- connecting cable bus phone



On the way home



TM Cleaning agents

We have a wide variety of cleaning agents for you to choose from.
We are happy to advise you – ask our specialists!

Cleaning agents

Cleaning agent for fresh and waste water tanks.

Cleaning agent for fresh water tanks with an optimal effect against algae and bacteria deposits. Foul smelling deposits are removed with active oxygen. Silver ions protect against recontamination and delay the build-up of new deposits. Also suitable for cleaning pipes, fittings and pumps.

Cleaning agent for waste water tanks with an optimal effect against deposits. Foul smelling deposits are removed with active oxygen grease solvents. With disinfection properties.

Cleaning agent for fresh water tanks



order no.:	89.6000.00.02
contents:	500 g (sufficient for 500 l)

Cleaning agent for waste water tanks



order no.:	89.6000.00.01
contents:	500 g (sufficient for 200 l)

Anti-limescale

Against limescale deposits and bad odours.

Highly effective tank care with citric acid against stubborn limescale deposits.

		<p>Anti-limescale</p> <hr/> <p>order no.: 89.6000.00.08</p> <hr/> <p>contents: 500 g</p>
---	--	---

Anti-freeze

Anti-freeze for fresh, cooling water or toilet systems.

Optimum protection against frost damage over the winter.

		<p>Anti-freeze</p> <hr/> <p>order no.: 89.6000.00.09</p> <hr/> <p>contents: 1 l (sufficient for 6 l service content)</p>
---	--	---

		<p>Anti-freeze concentrate</p> <hr/> <p>order no.: 89.6000.00.10</p> <hr/> <p>contents: 5 l</p>
---	--	--



1



2



3

1. Dashboard integrated cool box
2. QS Multiplus 2 G Kitchen
3. Transporter cool box
4. Summertime 2
5. Cool box KBU60
6. Central access toilet

TM Product landscape



4



5



6

TM Technischer Gerätebau GmbH

Böttgerstraße 13
89231 Neu-Ulm
Germany

phone +49 (0) 731 / 9 74 21-0
fax +49 (0) 731 / 9 74 21-69
e-mail vm@tmtech.de
homepage www.tmtech.de

Contact TM Germany sales and distribution national

spare parts +49 (0) 731 / 9 74 21-53
order transaction
manufacturer +49 (0) 731 / 9 74 21-57
customer service +49 (0) 731 / 9 74 21-41
fax +49 (0) 731 / 9 74 21-69

TM Teknik Otomotiv

Ekipmanları İthalat İhracat Sanayi ve Ticaret Ltd. Şti.
Gebze Organize Sanayi Bölgesi (GOSB)

1000.Cadde, No: 1009
41435, Çayırova, Kocaeli

Turkey

phone +90 (0) 262 / 677 11-52
fax +90 (0) 262 / 677 11-54
e-mail info@tmtech.com.tr
homepage www.tmtech.com.tr

Jincen-TM

Automotive Component Manufacturing Ltd.

Industrial Zone Shuangfeng Road

Hefei 23113

P.R. China

homepage www.jincen-tm.com

Our company is ISO 9001 certified.

Our products are tested according to the following standards:

Burning behavior according to ECE R118.

Electromagnetic compatibility according to ECE R10.

Energy absorption test according to ECE R21.

Bus comfort according to RAL-GZ 791.